

RANGE	CODE	MODEL	FUNCTION
MI - 70	MAMCOOO6660	FT76EMCST	Griddles

ITEM

Electric griddle top with 2/3 smooth and 1/3 ribbed chromed matt plate



TECHNICAL SPECIFICATIONS

WIDTH (mm):	600
DEPTH (mm):	750
HEIGHT (mm):	250
WEIGHT (Kg):	70
VOLUME (m ³):	0.3
EL. POWER (kW):	7.5
VOLTAGE:	VAC400-3N
COOKING ZONES N°:	1
COOKING ZONES DIM. (mm):	535x530 mm
COOKING ZONE DETAILS:	1x 7,5 kW
PRODUCT SPECIFICATIONS:	2/3 Smooth, 1/3 Ribbed Matt Chromed Plate
IP GRADE:	IPX5
TEMP. RANGE (°C):	0-280 °C

DESCRIPTION

Electric griddle in AISI 304 stainless steel. 20/10 pressed steel top with anti-spill front edge, designed for flush alignment with hermetic seal supplied. Top designed to accommodate water column accessory. Cooking surface with ChromePlus sloping hotplate 1/3 ribbed 2/3 smooth chrome finish. super-tough and easy-clean hotplate. Hotplate recessed 40 mm compared to worktop, fully welded construction for guaranteed ease of cleaning. Cooking surface with 65 mm cold zone at front of hotplate. Round Ø 40 mm drain hole for fat. Grease collection tub with 1.5 litre capacity. Heating by means of armoured elements in Incoloy. Heat control knob shaped to prevent water infiltration, equipped with integral indicator lights for instant recognition of heating and correct operation of the appliance. Cooking temperature thermostatically controlled, with adjustment from 110 to 280 °C. Safety thermostat trips in the event of working thermostat malfunction. Cooking surface 535x530 mm. Scraper supplied for smooth hotplate. The product complies with EC regulation 1935/2004 and Italian ministerial decree 21/03/1973 (Materials and Objects intended to come into contact with Food) MOCA. IPX5 water-resistant rating.



RANGE	CODE	MODEL	FUNCTION
MI - 70	MAMCOOO666O	FT76EMCST	Griddles

ITEM

Electric griddle top with 2/3 smooth and 1/3 ribbed chromed matt plate

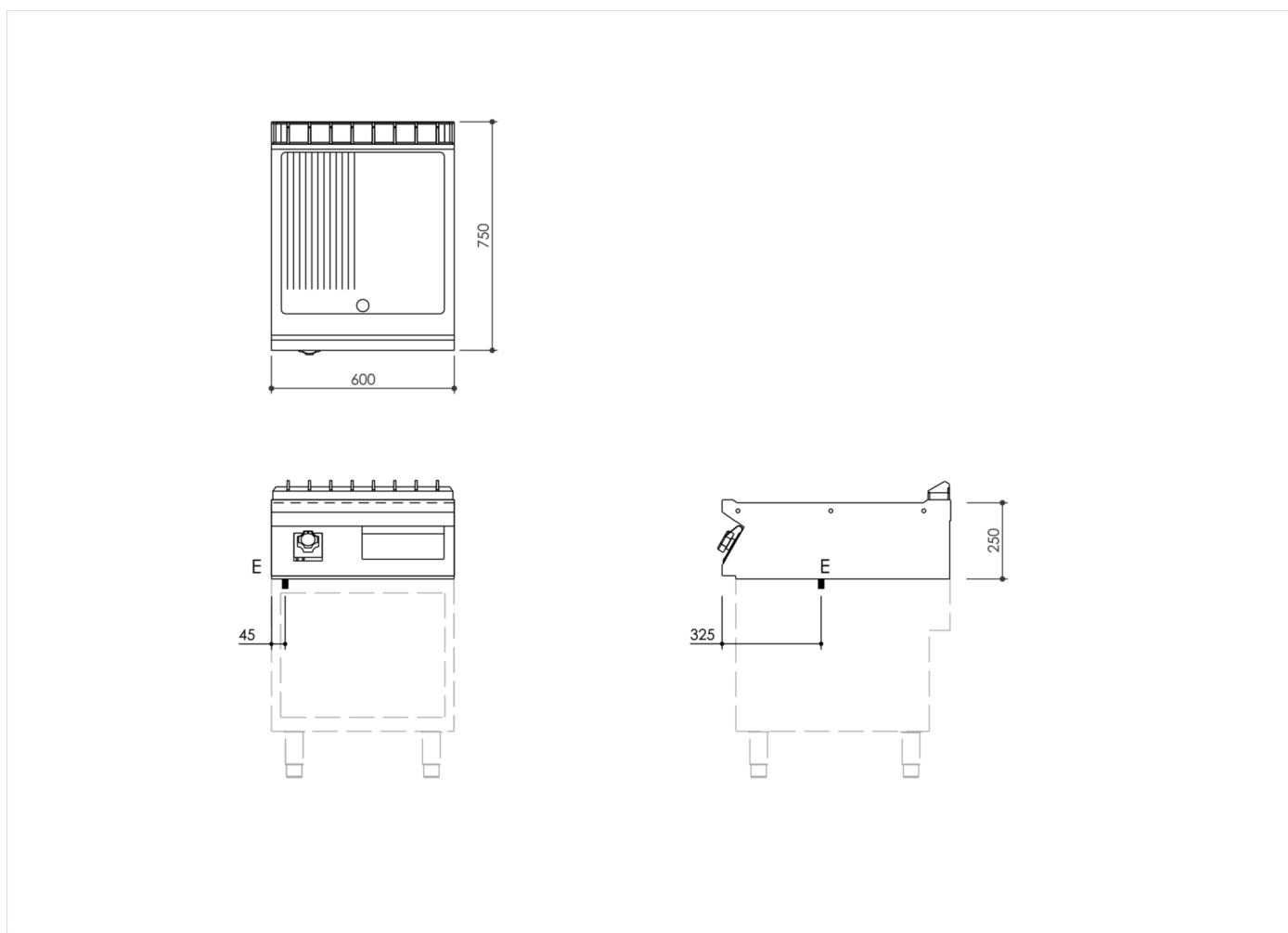

INSTALLATION SPECIFICATIONS

(E) Electrical Connection: VAC400-3N 50/60 Hz

