

RANGE

Convection and Combination Ovens MO

MODEL

MICETO7IE

FUNCTION

MO ovens - 7x GN I/I

ITEM

Electric direct steam combi oven 7 x GN I/I



RANGE

Convection and Combination Ovens MO

MODEL

MICETO7IE

FUNCTION

MO ovens - 7x GN I/I

ITEM

Electric direct steam combi oven 7 x GN I/I

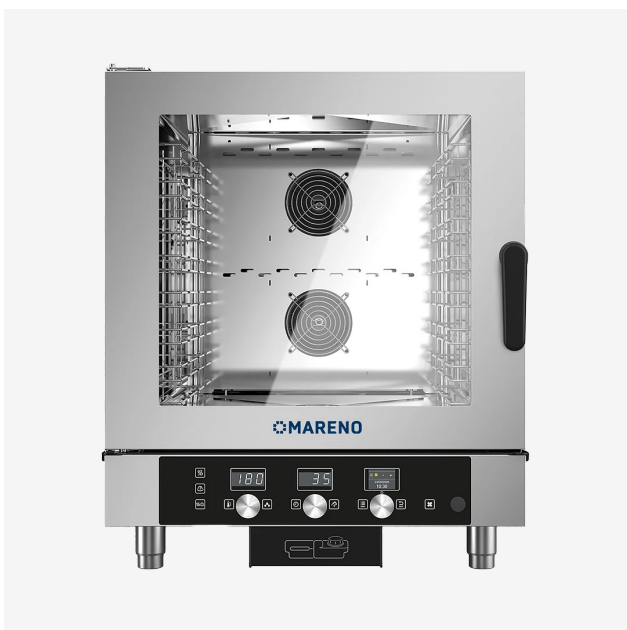

**TECHNICAL SPECIFICATIONS**

WIDTH (mm):	<b>777</b>
DEPTH (mm):	<b>729</b>
HEIGHT (mm):	<b>942</b>
WEIGHT (Kg):	<b>90</b>
VOLUME (m <sup>3</sup> ):	<b>0.55</b>
EL. POWER (kW):	<b>12.5</b>
VOLTAGE:	<b>VAC400 3N</b>
OVEN CAPACITY:	<b>7x GN I/I</b>
GN TRAY SPACING	<b>70</b>
NUMBER OF MEALS	<b>50/120</b>
TRAY CAPACITY EN	<b>7 x 600 x 400</b>
NUMBER OF CROISSANTS	<b>84/112</b>





RANGE

Convection and Combination Ovens MO

MODEL

MICETO7IE

FUNCTION

MO ovens - 7x GN I/I

ITEM

Electric direct steam combi oven 7 x GN I/I

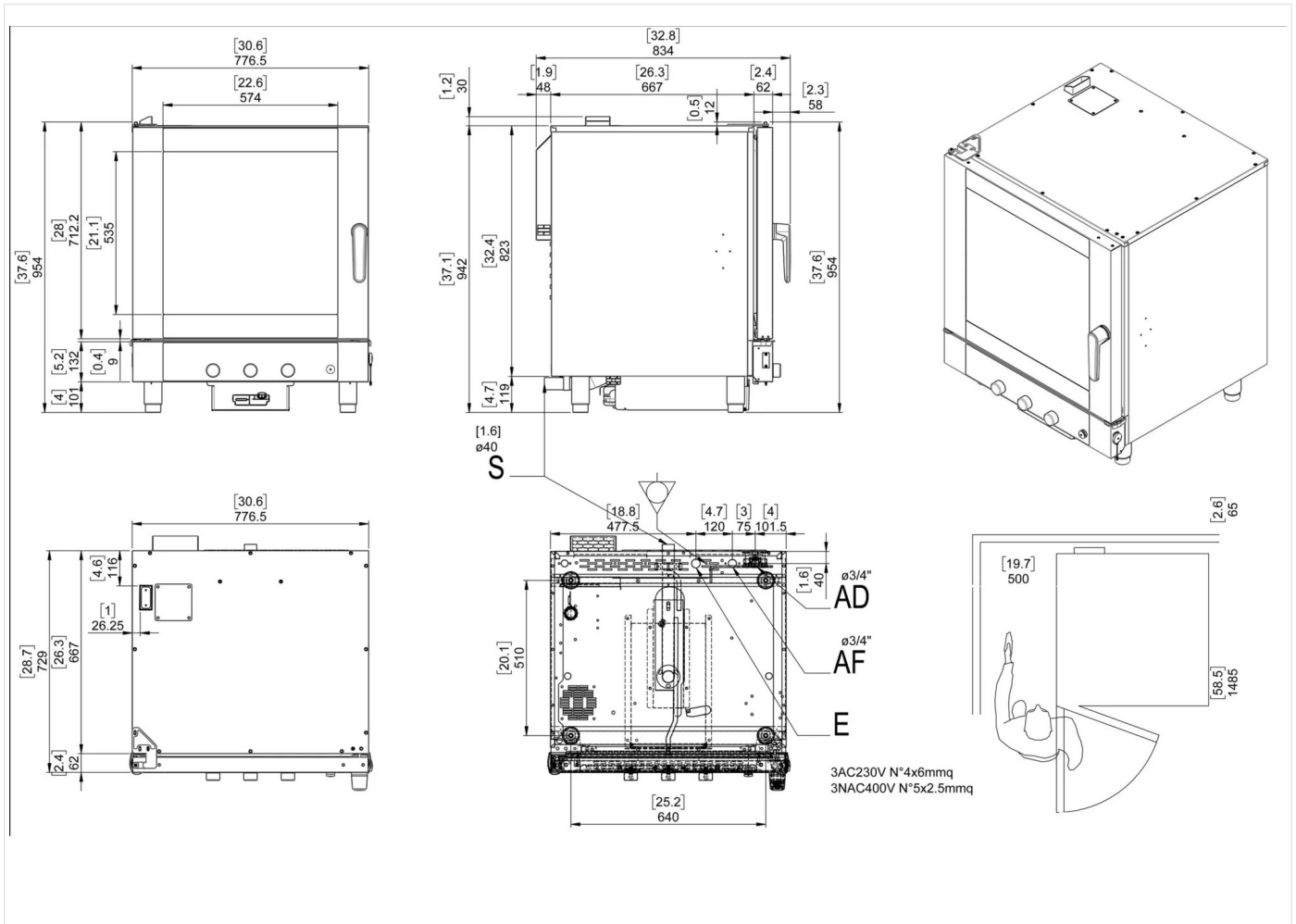

## INSTALLATION SPECIFICATIONS

(E) Electrical Connection: VAC400 3N 50/60Hz

(AD) Softened Water Inlet: Ø3/4

(AD) Softened Water Inlet: Ø3/4

