

RANGE

MO Compact Combi Ovens

MODEL

MICCMO26E

FUNCTION

MO Ovens - 6x GN 2/3

ITEM

Electromechanical direct steam combi oven 6 x GN 2/3



RANGE

MO Compact Combi Ovens

MODEL

MICCMO26E

FUNCTION

MO Ovens - 6x GN 2/3

ITEM

Electromechanical direct steam combi oven 6 x GN 2/3

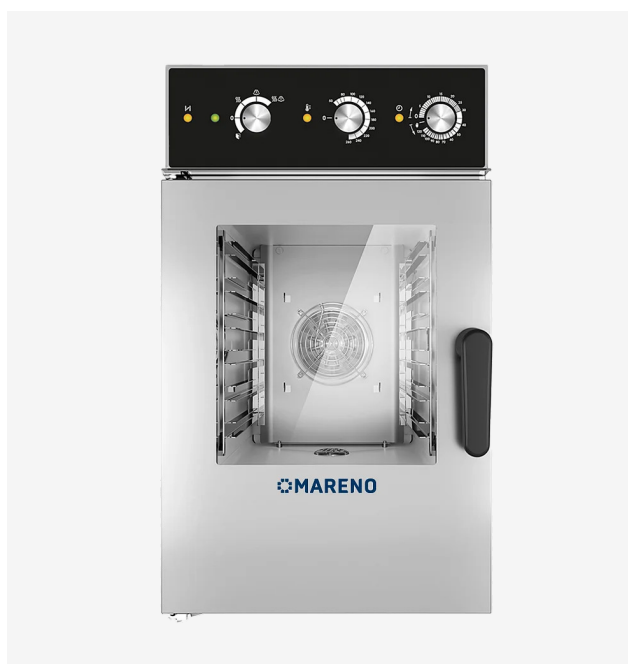

TECHNICAL SPECIFICATIONS

WIDTH (mm):	510
DEPTH (mm):	625
HEIGHT (mm):	880
WEIGHT (Kg):	59
VOLUME (m ³):	0.3
EL. POWER (kW):	5.25
VOLTAGE:	VAC400 3N
OVEN CAPACITY:	6 X 2/3 GN
GN TRAY SPACING	60
NUMBER OF MEALS	20/50



RANGE

MO Compact Combi Ovens

MODEL

MICCMO26E

FUNCTION

MO Ovens - 6x GN 2/3

ITEM

Electromechanical direct steam combi oven 6 x GN 2/3**DESCRIPTION**

Electric direct steam combi oven. Cooking methods: manual cooking with three cooking modes: Convection from 50°C to 260°C, Steam from 50°C to 130°C, Combined from 50°C to 260°C. control panel with manual switchgear and operation mode control lights. Autoreverse (automatic inversion of the direction of the fan) for perfectly uniform cooking. Manual chamber venting. LED chamber lighting. Perfectly smooth cooking chamber walls with rounded edges. Double-glazed door with thermoreflective tempered glass, with an air cavity to prevent heat radiation towards users and for increased efficiency. Left or right-hand opening handle. Adjustable hinges for optimal grip. Extractable deflector for ease of cleaning of the fan bay. IPX3 water jet protection. Electric heating system: cooking compartment heating elements of armoured type. Standard equipment side runners, space between shelves 70mm. Cooking chamber capacity: 6x GN 2/3 (325x355mm). Number of meals 20 - 50.



RANGE

MO Compact Combi Ovens

MODEL

MICCMO26E

FUNCTION

MO Ovens - 6x GN 2/3

ITEM

Electromechanical direct steam combi oven 6 x GN 2/3

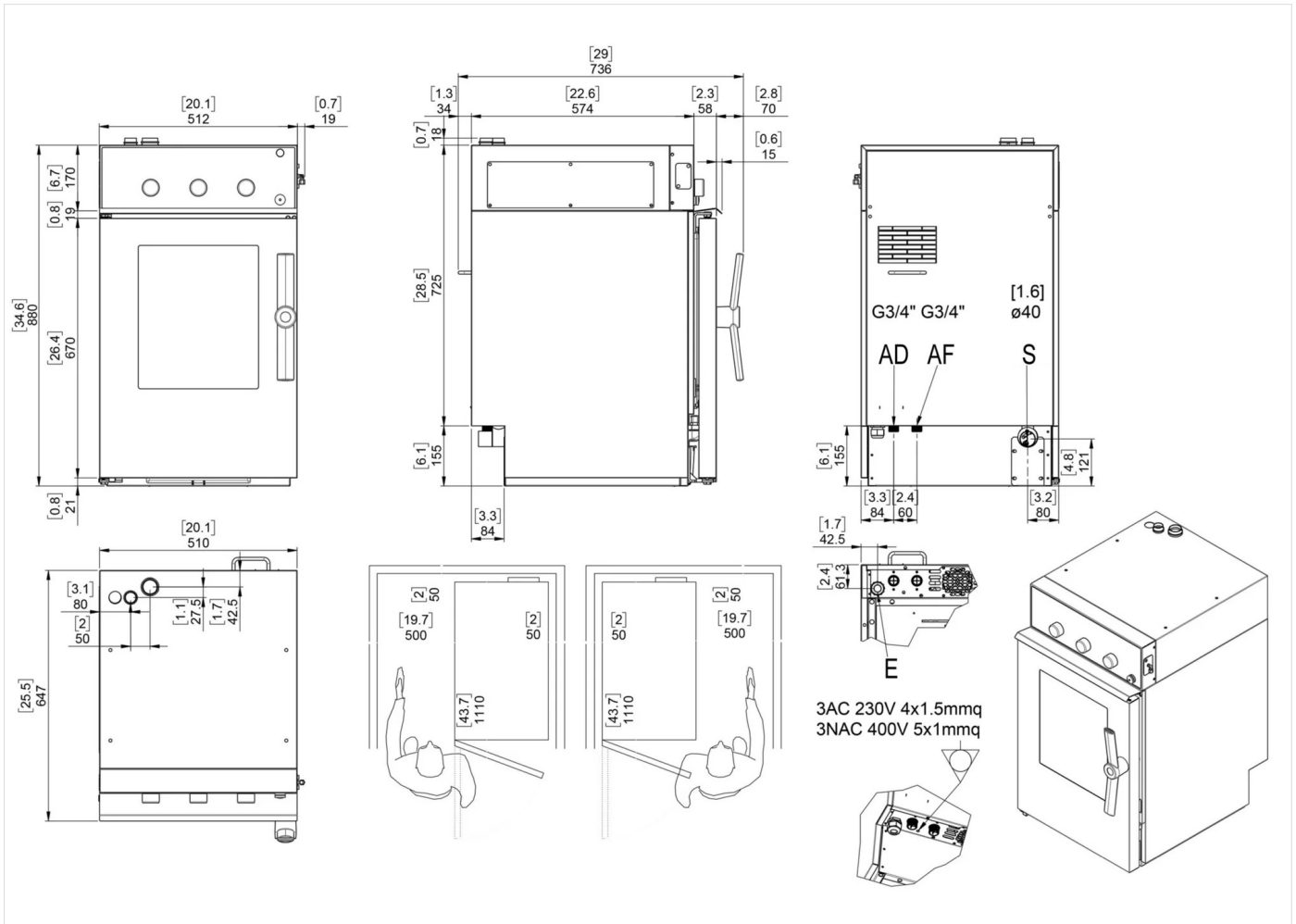

INSTALLATION SPECIFICATIONS

(E) Electrical Connection: VAC400 3N 50/60Hz

(AD) Softened Water Inlet: Ø3/4

(AD) Softened Water Inlet: Ø3/4

