

RANGE	CODE	MODEL	FUNCTION
MI - 70	MAMCOOO1490	FT712GMCT	Griddles

ITEM

Gas griddle top with 2/3 smooth and 1/3 ribbed chromed plate

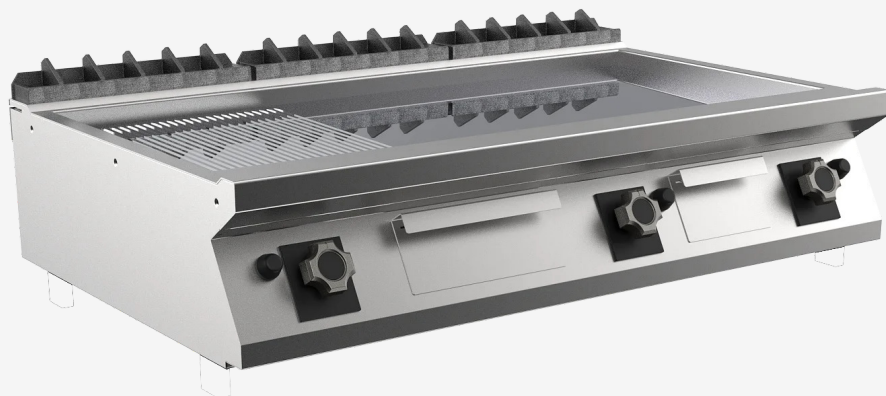

RANGE	CODE	MODEL	FUNCTION
MI - 70	MAMCOOO1490	FT712GMCT	Griddles

ITEM

Gas griddle top with 2/3 smooth and 1/3 ribbed chromed plate



TECHNICAL SPECIFICATIONS

WIDTH (mm):	1200
DEPTH (mm):	750
HEIGHT (mm):	250
WEIGHT (Kg):	141
VOLUME (m ³):	0.6
GAS POWER (kW):	21
COOKING ZONES N°:	3
COOKING ZONES DIM. (mm):	1135x530 mm
COOKING ZONE DETAILS:	3x 7 kW
PRODUCT SPECIFICATIONS:	2/3 Smooth, 1/3 Ribbed Chromed Plate
TEMP. RANGE (°C):	0-280 °C

DESCRIPTION

Gas griddle in AISI 304 stainless steel. 20/10 pressed steel top with anti-spill front edge, designed for flush alignment with hermetic seal supplied. Top designed to accommodate water column accessory. Cooking surface with sloping mirror-polished hotplate, 1/3 ribbed 2/3 smooth. Hotplate recessed 40 mm compared to worktop, fully welded construction for guaranteed ease of cleaning. Cooking surface with 65 mm cold zone at front of hotplate. Round Ø 40 mm drain hole for fat. Grease collection tub with 1.5 litre capacity. Heating by means of steel stabilised flame burner having 2 branches and 4 rows of flames for each zone, complete with pilot flame and safety thermocouple. Heating control knob shaped to prevent water infiltration. Gas supply controlled by thermostatic valve with safety thermocouple. Cooking temperature manually controlled from 90°C to 280°C. Automatic ignition by means of piezoelectric device with waterproof cap. Cooking surface 1135x530 mm. Scraper supplied for smooth hotplate. The product complies with EC regulation 1935/2004 and Italian ministerial decree 21/03/1973 (Materials and Objects intended to come into contact with Food) MOCA.



RANGE	CODE	MODEL	FUNCTION
MI - 70	MAMCOOO1490	FT712GMCT	Griddles

ITEM

Gas griddle top with 2/3 smooth and 1/3 ribbed chromed plate

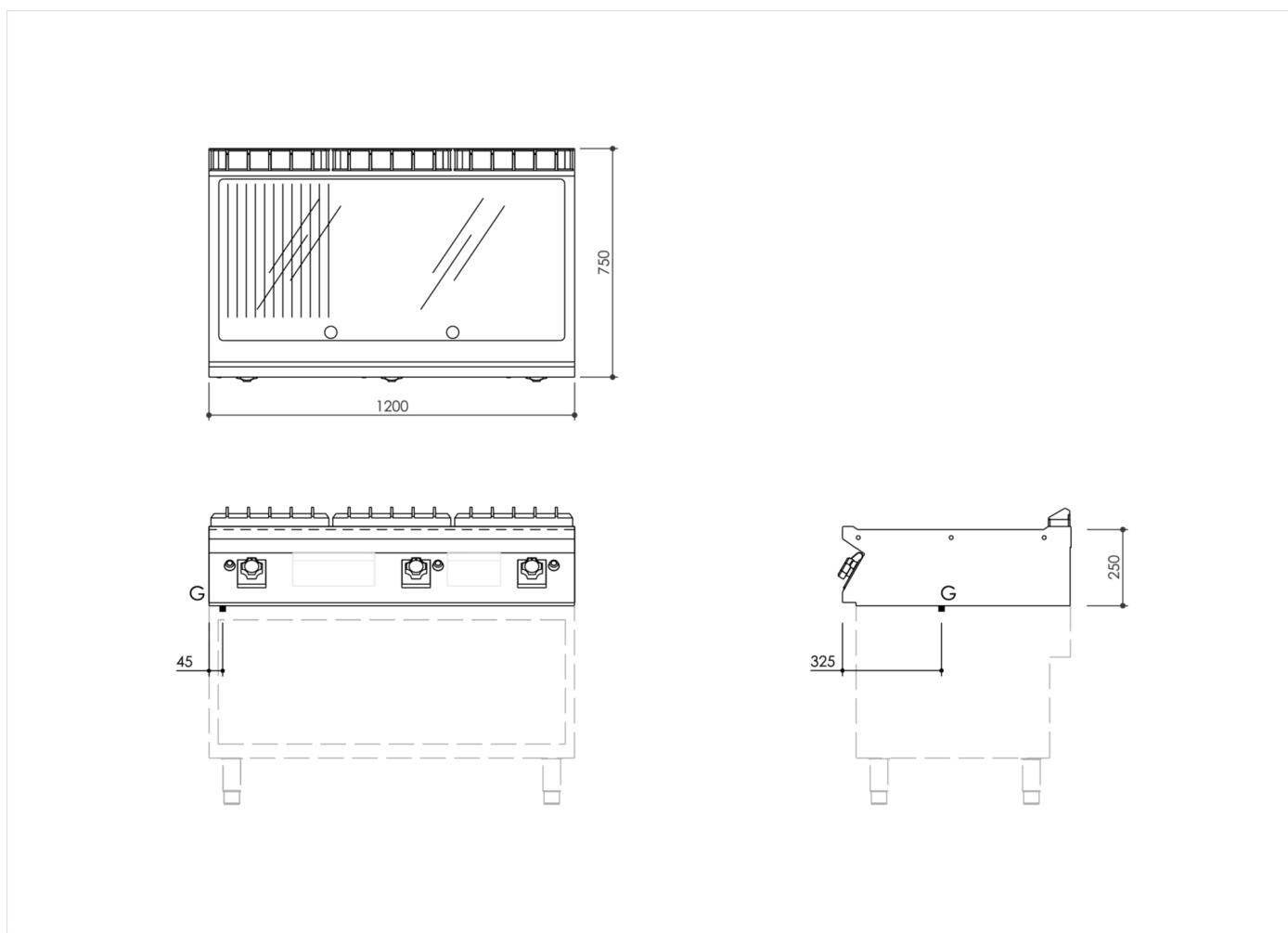

INSTALLATION SPECIFICATIONS

(G) Gas Inlet: $\text{Ø}1/2''$

