

RANGE

Rack conveyor dishwashers

CODE

CRI300560

MODEL

MRXCI64ED

ITEM

Rack conveyor Dishwasher RX Compact Electric version - Rh with pre-rinse module



RANGE

Rack conveyor dishwashers

CODE

CRI300560

MODEL

MRXCI64ED

ITEM

Rack conveyor Dishwasher RX Compact Electric version - Rh with pre-rinse module



TECHNICAL SPECIFICATIONS

WIDTH (mm):	1880
DEPTH (mm):	715
HEIGHT (mm):	1565
WEIGHT (Kg):	270
VOLUME (m ³):	2
GAS POWER (kW):	0
EL. POWER (kW):	23.6
VOLTAGE (V):	400V 3N
FREQUENCY (Hz):	50 Hz
BASKET SIZE (mm):	500x500
MAX PLATE DIAMETER (mm):	450
GN/EN:	GN I/I

SEC./CYCLE

BASKETS/HOUR - 10°C



RANGE

Rack conveyor dishwashers

CODE

CRI300560

MODEL

MRXCI64ED

ITEM

Rack conveyor Dishwasher RX Compact Electric version - Rh with pre-rinse module**DESCRIPTION**

Electric dishwasher with basket feed-through. Made of stainless steel AISI 304. Pre-wash, wash and rinse feed from right to left. Rounded stainless steel tanks. Self-cleaning vertical wash pumps, protected against electrical overloads. Double side traction system with built-in clutch that prevents derailment. AISI 304 stainless steel boilers, resistant to chemical aggression, fully insulated to reduce thermal losses. Simple and intuitive low-voltage touch screen control panel with IP65 protection rating, built with membrane keypad for easy cleaning. Stainless steel washing and rinsing arms, removable without the use of tools both for ordinary cleaning operations and to facilitate the change of direction. Stainless steel surface filters on all tanks, easily removable without detaching washing arms, to keep the water clean and free from food scraps. Insulated double skin door, counterbalanced, equipped with anti-drop safety system. Two speed traction system with built-in clutch. Variable speed inverter available on request, to vary the conveyor speed when needed. Autotimer in order to switch off the rack conveyor motor as well as any electrical options after a pre-set period of inactivity, allowing consumption to be reduced. Wash and rinse economisers. They are only activated when baskets are in the designated area, avoiding waste of water. Pressure reducer to optimise the mains pressure, stabilising it for optimal rinsing and reduced consumption. Non-return valve to prevent backflow of dishwasher water into the water mains, preventing contamination in the event of an external low pressure. 100/150 Baskets/hour. Pre-wash pump kW 0.9. Washing pump kW 1.5. Boiler heating element kW 12. Tank heating element kW 9. Pre-rinse tank capacity lt. 40. Washing tank capacity lt. 80. Boiler capacity lt. 28,5. Water consumption lt. 260. Basket size 500x500 cm. Useful height mm. 450. Standard accessories: 1 x Dish basket, 1 x Glass basket, 1 x Cutlery basket 8 places, 1 x Tray basket.



RANGE

Rack conveyor dishwashers

CODE

CRI30O56O

MODEL

MRXCI64ED

ITEM

Rack conveyor Dishwasher RX Compact Electric version - Rh with pre-rinse module

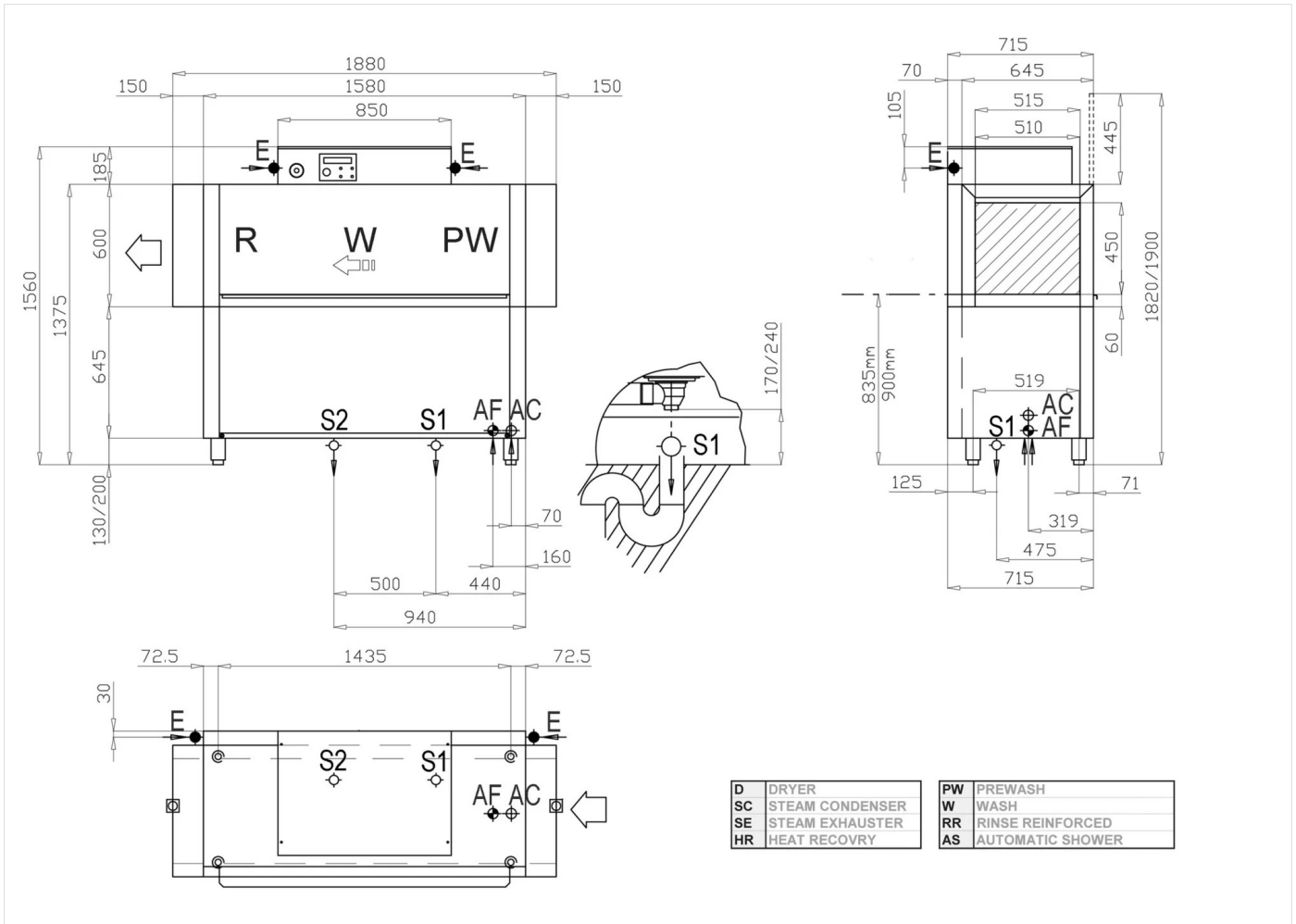

INSTALLATION SPECIFICATIONS

(E) Electrical Connection:	400V 3N 50 Hz
(AF) Cold Water Inlet:	Ø3/4-H=150mm
(AC) Hot Water Inlet:	Ø3/4-H=150mm-60°C(2/4bar)
(S) Output Drain:	Ø1 1/4-H=170/240mm.

