

RANGE	CODE	MODEL	FUNCTION
MI - 70	MAMCOOO2040	FT78ELCG	Griddles

ITEM

Electric griddle top with smooth chromed plate on open stand



RANGE	CODE	MODEL	FUNCTION
MI - 70	MAMCOOO2040	FT78ELCG	Griddles

ITEM

Electric griddle top with smooth chromed plate on open stand



TECHNICAL SPECIFICATIONS

WIDTH (mm):	800
DEPTH (mm):	750
HEIGHT (mm):	900
WEIGHT (Kg):	108
VOLUME (m ³):	0.8
EL. POWER (kW):	10.8
VOLTAGE:	VAC400-3N
INTERNAL BASE UNIT DIM. (mm):	720x400(h)x700 mm
COOKING ZONES N°:	2
COOKING ZONES DIM. (mm):	735x530 mm
COOKING ZONE DETAILS:	2x 5,4 kW
PRODUCT SPECIFICATIONS:	Smooth Chromed Plate
IP GRADE:	IPX5
TEMP. RANGE (°C):	0-280 °C

DESCRIPTION

Freestanding electric griddle on open cabinet base, in AISI 304 stainless steel. 20/10 pressed steel top with anti-spill front edge, designed for flush alignment with hermetic seal supplied. Top designed to accommodate water column accessory. Cooking surface with smooth mirror-polished chrome hotplate. Hotplate recessed 40 mm compared to worktop, fully welded construction for guaranteed ease of cleaning. Cooking surface with 65 mm cold zone at front of hotplate. Round Ø 40 mm drain hole for fat. Fat collection GN container located in lower compartment to assist and increase the liquid collection capacity. Heating by means of armoured elements in Incoloy. Heat control knob shaped to prevent water infiltration, equipped with integral indicator lights for instant recognition of heating and correct operation of the appliance. Cooking temperature thermostatically controlled, with adjustment from 110 to 280 °C. Safety thermostat trips in the event of working thermostat malfunction. Cooking surface 735x530 mm. Scraper supplied for smooth hotplate. The product complies with EC regulation 1935/2004 and Italian ministerial decree 21/03/1973 (Materials and Objects intended to come into contact with Food) MOCA. IPX5 water-resistant rating. Appliance equipped with stainless steel adjustable feet.



RANGE	CODE	MODEL	FUNCTION
MI - 70	MAMCOOO2040	FT78ELCG	Griddles

ITEM

Electric griddle top with smooth chromed plate on open stand

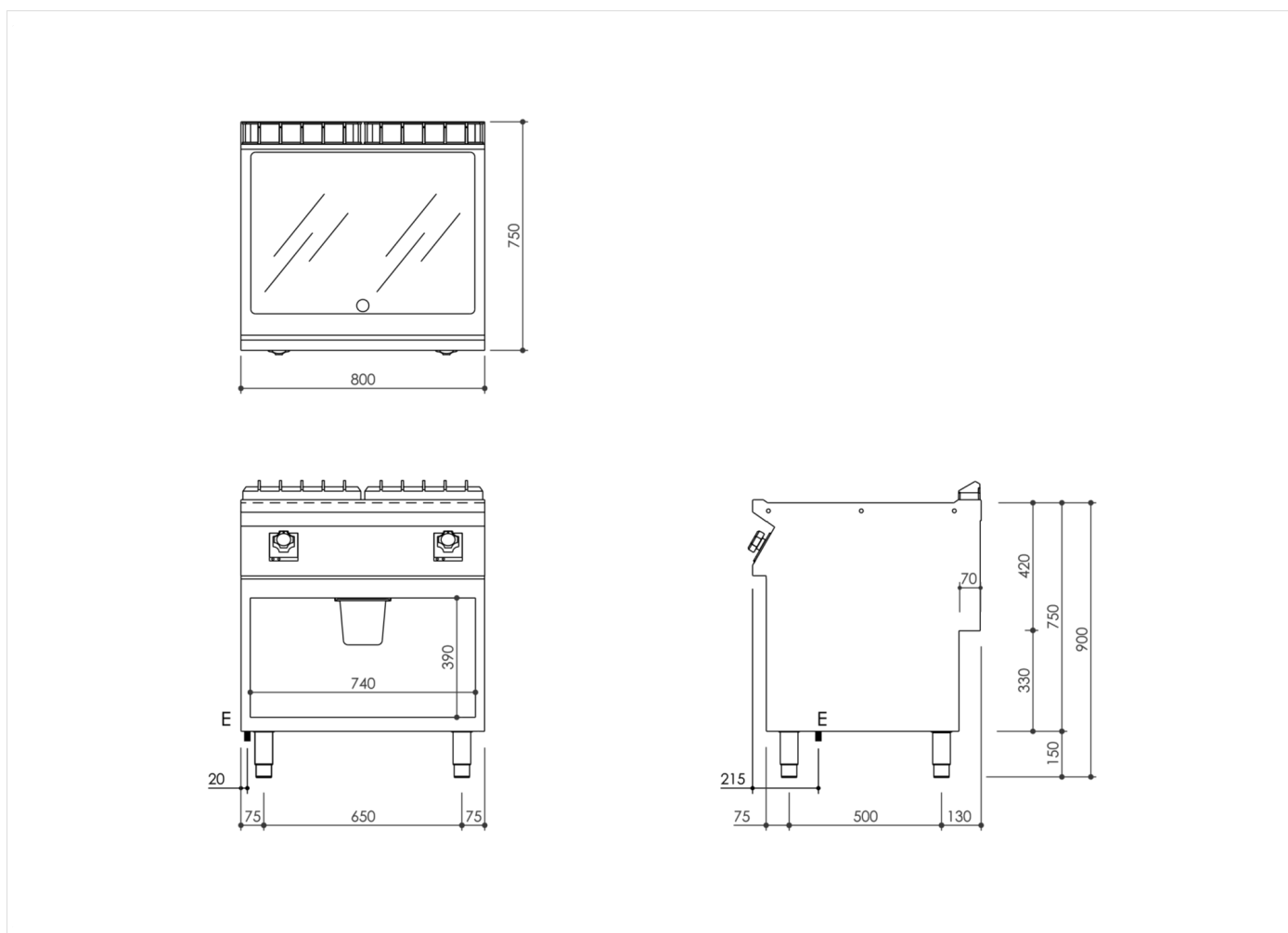

INSTALLATION SPECIFICATIONS

(E) Electrical Connection: **VAC400-3N 50/60 Hz**

