

RANGE	CODE	MODEL	FUNCTION
MI - 70	MAMCOOOO620	FR76EIOKT	Fryers

ITEM

Twin pan electric fryer IO+ IO litres top with electronic controls



TECHNICAL SPECIFICATIONS

WIDTH (mm):	600		
DEPTH (mm):	750		
HEIGHT (mm):	250		
WEIGHT (Kg):	41		
VOLUME (m ³):	0.3		
EL. POWER (kW):	18		
VOLTAGE:	VAC400 3N		
COOKING ZONES N°:	2		
COOKING ZONE DETAILS:	2x 9 kW		
TANK N°:	2	CAPACITY (L):	2x 10
IP GRADE:	IPX5		
TEMP. RANGE (°C):	90-185		

DESCRIPTION

Electric fryer top with electronic temperature control, in AISI 304 stainless steel. 20/10 pressed steel top with anti-spill front edge, designed for flush alignment with hermetic seal supplied. Tank capacity 10+10 litres. Tanks with wide front expansion zone for oil and foam and extended cold zone for collection of food particles. Supplied with front drainage. Heating by means of an armoured immersion-type heating element in AISI 304 stainless steel. The element can be rotated by over 90° to facilitate tank cleaning. Tank oil temperature adjustable from 100 to 185 °C. 3 digit display, Melting cycle. Heat control thermostat with shape designed to prevent water infiltration, with integral indicator lights for instant recognition of appliance operation. Fryer equipped with manual reset safety thermostat that trips in overtemperature conditions. Removable filter, basket, lid and pipe for supplied drain tap. IPX5 water-resistant rating.



RANGE	CODE	MODEL	FUNCTION
MI - 70	MAMCOOOO620	FR76EIOKT	Fryers

ITEM

Twin pan electric fryer 10+ 10 litres top with electronic controls

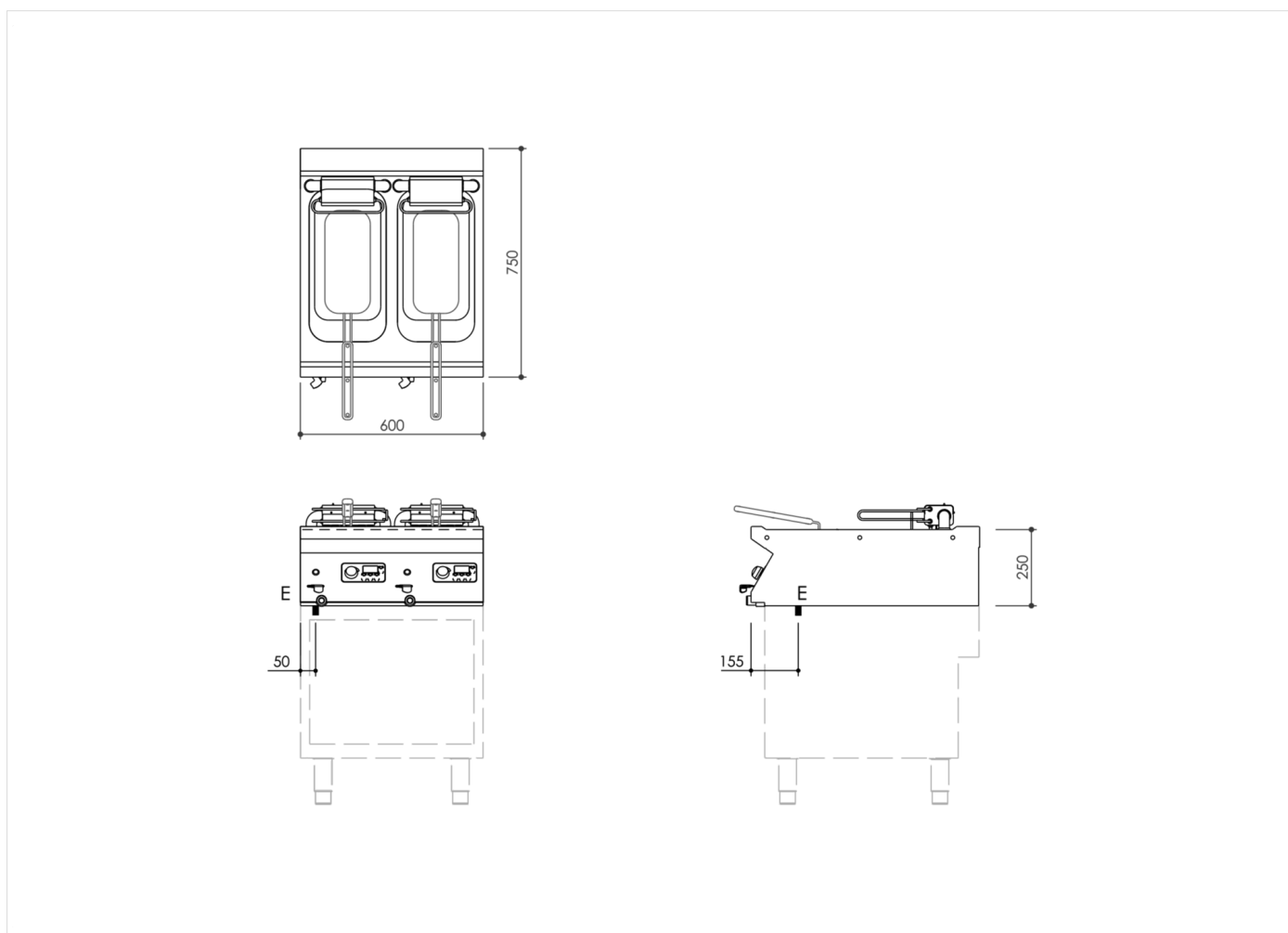

INSTALLATION SPECIFICATIONS

(E) Electrical Connection: **VAC400 3N 50 / 60 Hz**

