

RANGE	CODE	MODEL	FUNCTION
MI - 60	CRI30I770	FT66EL2	Griddles

ITEM

Electric griddle top with smooth plate



RANGE	CODE	MODEL	FUNCTION
MI - 60	CR1301770	FT66EL2	Griddles

ITEM

Electric griddle top with smooth plate



TECHNICAL SPECIFICATIONS

WIDTH (mm):	600
DEPTH (mm):	600
HEIGHT (mm):	295
WEIGHT (Kg):	56
VOLUME (m ³):	0.3
EL. POWER (kW):	7.8
VOLTAGE:	VAC230-3
COOKING ZONES N°:	2
COOKING ZONES DIM. (mm):	596x555mm
COOKING ZONE DETAILS:	2x 3,9kW
PRODUCT SPECIFICATIONS:	Smooth Inox AISI 430 Plate
IP GRADE:	IPX3
TEMP. RANGE (°C):	50-300

DESCRIPTION

Electric griddle with smooth plate in stainless steel Aisi 430. Equipment made of stainless steel. Equipped with splash guard on three sides and front channel with removable tray for grease collection. Heating by means of armoured heating elements placed under the plate. Two independent cooking zones controlled by adjustable thermostat from 0°C to 300°C. Safety thermostat with manual reset. Cooking surface mm 596x555. Stainless steel shovel included. The product complies with EC Regulation 1935/2004 and DM 21/03/1973 (Materials and articles intended to come into contact with food) MOCA.



RANGE	CODE	MODEL	FUNCTION
MI - 60	CR130I770	FT66EL2	Griddles

ITEM

Electric griddle top with smooth plate

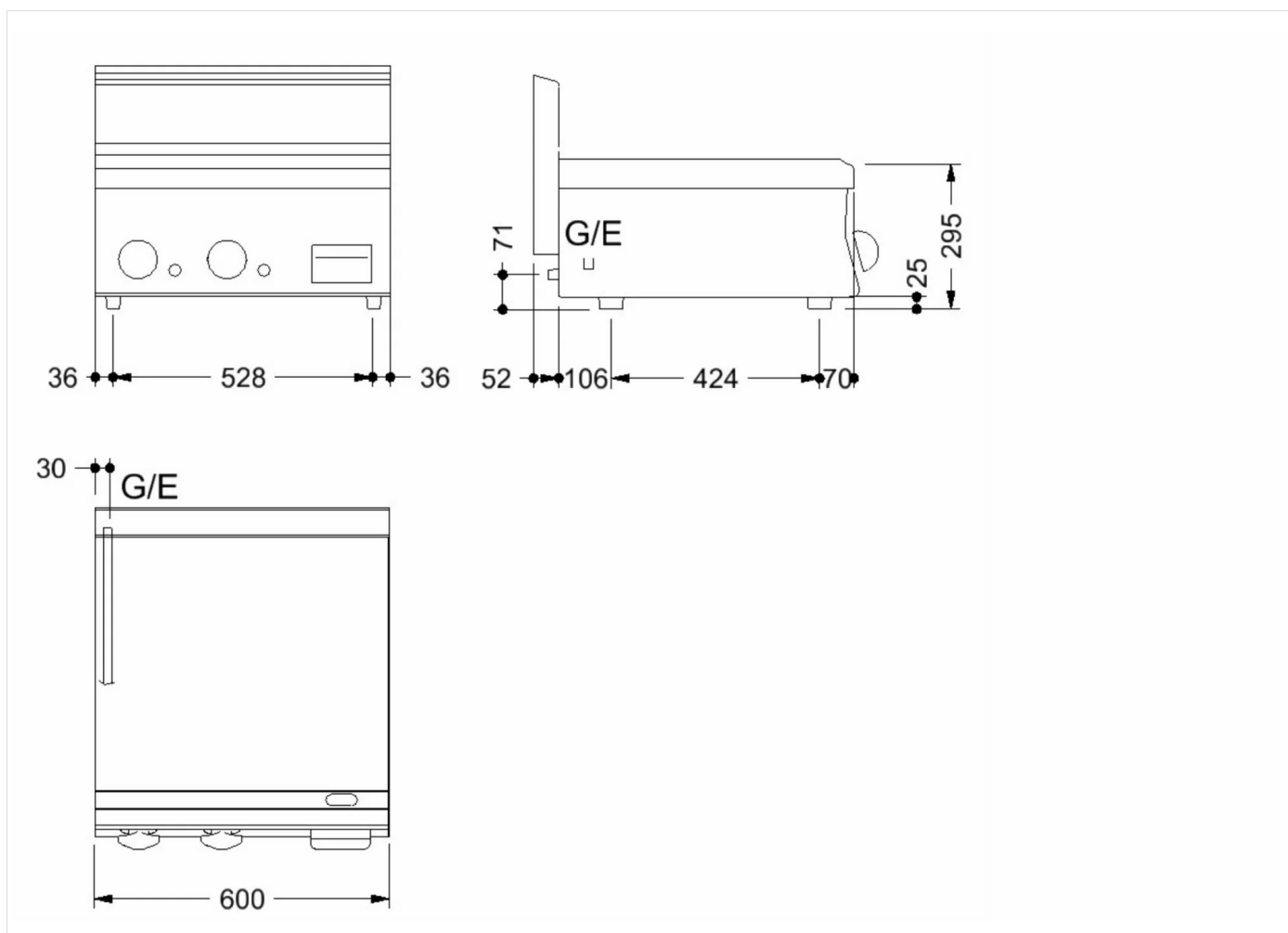

INSTALLATION SPECIFICATIONS

(E) Electrical Connection: VAC230-3 50/60Hz

