

RANGE	CODE	MODEL	FUNCTION
MI - 90	MAMCOOO3I30	WK9I2GG	Gas Ranges

ITEM

Double gas 14+14 kW wok burner on open stand



RANGE	CODE	MODEL	FUNCTION
MI - 90	MAMCOOO3I30	WK9I2GG	Gas Ranges

ITEM

Double gas 14+14 kW wok burner on open stand



TECHNICAL SPECIFICATIONS

WIDTH (mm):	1200
DEPTH (mm):	920
HEIGHT (mm):	900
WEIGHT (Kg):	96
VOLUME (m ³):	0.9
GAS POWER (kW):	28
INTERNAL BASE UNIT DIM. (mm):	1080x400(h)x900 mm
COOKING ZONES N°:	2
COOKING ZONES DIM. (mm):	2x Ø 215 mm

DESCRIPTION

Freestanding wok range featuring 2 high-yield burners with vertical flame, for uniform heating of the wok and perfectly cooked food. 2 x 14 kW burner in enamelled cast iron measuring Ø 190 mm with venturi system in stainless steel, removable for easy cleaning and maintenance. Cooktop in reinforced AISI 304 stainless steel, thickness 20/10. Power adjustment by means of a safety tap with thermocouple. Main burner ignition by means of a permanent pilot burner. Wok pan stand grille Ø 275 mm manufactured in enamelled cast iron with Ø 410 mm base. 1150x720 mm top with recessed spillage well and rear drain to right Ø 22 mm equipped for connection to drainage system, option water filling system for cooling and cleaning of top. Removable grease collection tray positioned below burners. Appliance equipped with height adjustable feet in stainless steel.



RANGE	CODE	MODEL	FUNCTION
MI - 90	MAMCOOO3I30	WK9I2GG	Gas Ranges

ITEM

Double gas 14+14 kW wok burner on open stand

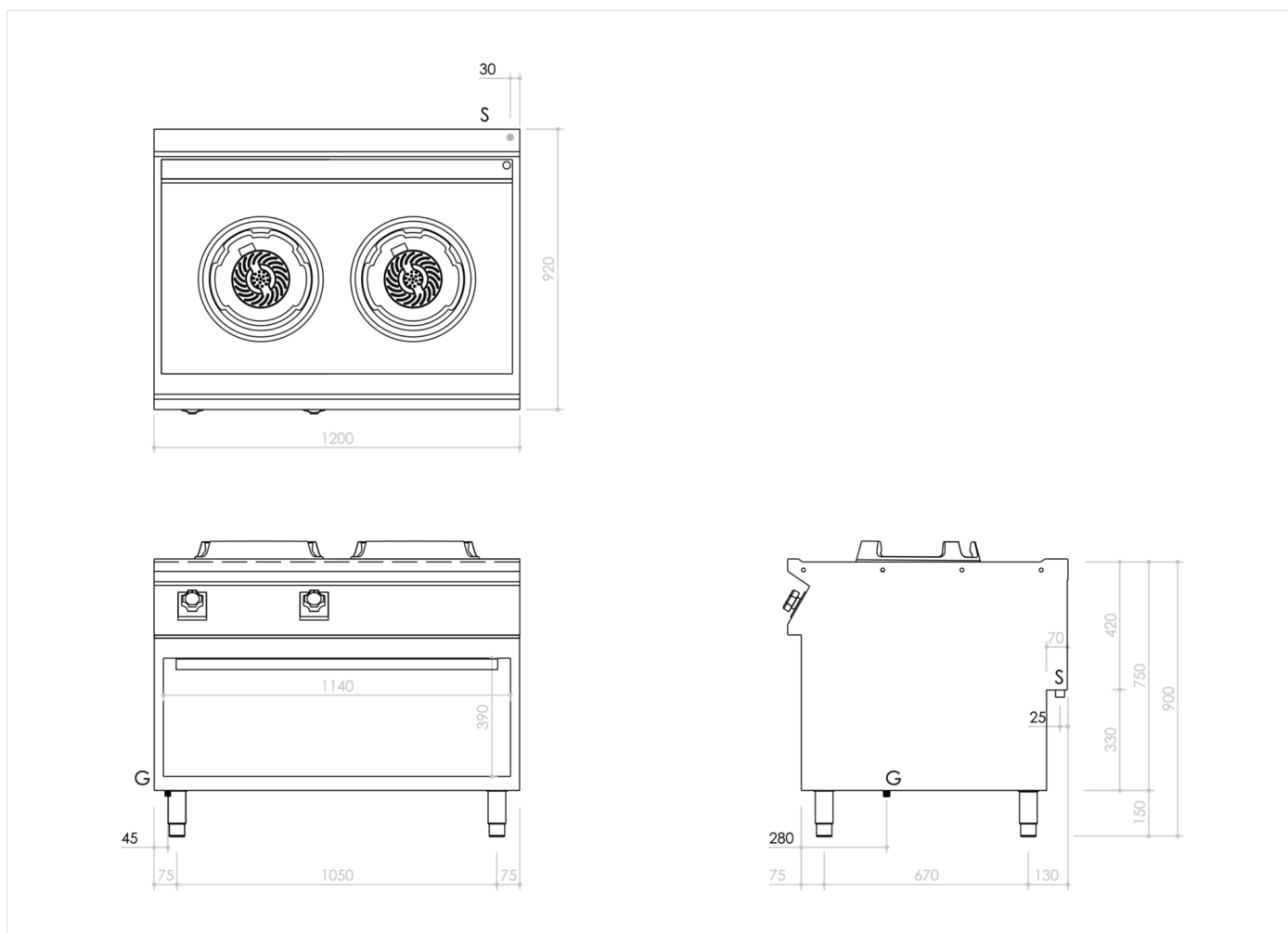

INSTALLATION SPECIFICATIONS

(G) Gas Inlet: $\text{Ø}1/2''$

