

RANGE	CODE	MODEL	FUNCTION
MI - 90	MAMCOOO4280	FT96ELCT	Griddles

ITEM

Electric griddle top with smooth chromed plate



RANGE	CODE	MODEL	FUNCTION
MI - 90	MAMCOOO4280	FT96ELCT	Griddles

ITEM

Electric griddle top with smooth chromed plate

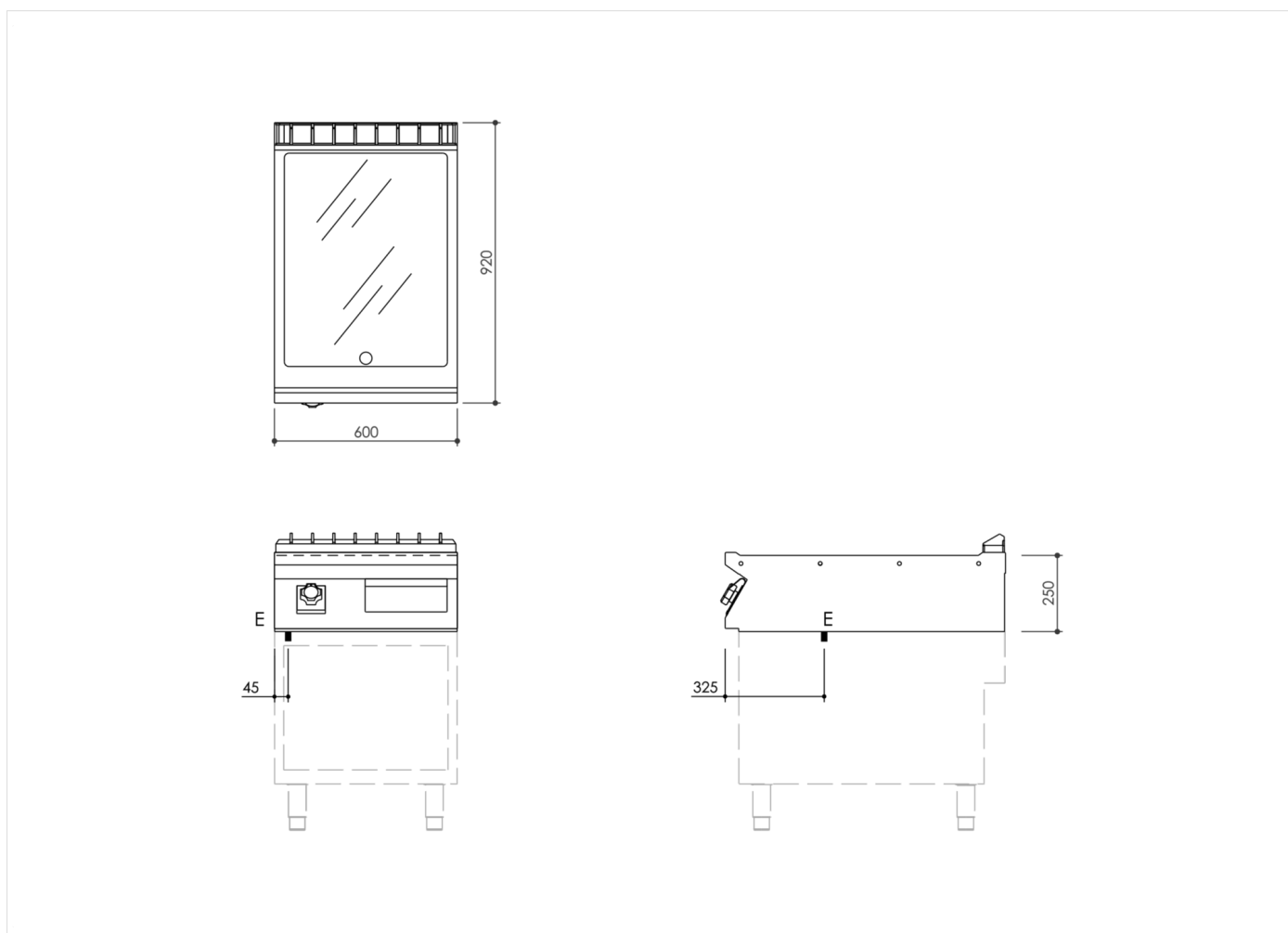

INSTALLATION SPECIFICATIONS

(E) Electrical Connection: **VAC400-3N 50/60Hz**

